

La belleza de la simplicidad. TWork







TWork permite compartir tu puesto de trabajo, incorporando soluciones acústicas para mejorar el confort.

TWork pour un partage des tables de travail en tout confort grâce à l'intégration de solutions acoustiques.

TWork enables workstation sharing and adds acoustic solutions to enhance comfort.







---

Configuraciones de trabajo que incorporan nuevas soluciones de archivo personalizado y electrificación para mesas multipuesto.

Compositions offrant de nouvelles solutions de personnalisation du classement et d'électrification des tables multipostes.

Work compositions that add new custom filing solutions and electrification for multi-user desks.









The beauty of

# Simmetry

---

Las formas principales de la belleza, son la simetría,  
el tamaño, el orden y la delimitación.

*Aristóteles*

Les principales formes de beauté sont la  
symétrie, la dimension, l'ordre et le contour.

*Aristóteles*

The major aspects of beauty are symme-  
try, size, order and spatial definition.

*Aristóteles*

The beauty of

# Symmetry



Las formas principales de la belleza son la simetría,  
el tamaño, el orden y la delimitación.  
Aristóteles

Les principales formes de beauté sont la  
symétrie, la dimension, l'ordre et le contour.  
Aristóteles

The major aspects of beauty are symme-  
try, size, order and spatial definition.  
Aristóteles





---

Equilibrio estético en las composiciones con doble pata para benches de mesas con ala.

Équilibre esthétique dans les compositions sur pied double pour les benches constitués de tables avec retour.

Aesthetically balanced, double leg configurations for bench desks with return.





URBAN DESIGN  
FINE WINES

DOMALDESIGN 2014

THE ALLURE OF BEAUTY

FASHION DESIGN  
THE ALLURE OF MEN  
A SMILE IN THE MIND  
THE ALLURE OF WOMEN  
ARCHITECTURE  
UHADS  
THE BOOK OF SYMBOLS  
THE FASHION BOOK

Módulo auxiliar operativo "MAC" y carril compartido que permite organizar y dividir los espacios de trabajo.

Module auxiliaire opérationnel "MAC" avec une zone commune permettant d'organiser et de diviser l'espace de travail.

Auxiliary module "MAC" and shared track that enables you to organise and divide work space.







La serie ofrece también composiciones clásicas de mesa con forma y cajonera incorporada.

La gamme offre également des compositions classiques de tables intégrant plateau et caisson.

The series also offers classic compositions of shaped desks with integrated drawer unit.





Creating

# Balance

---

La elegancia es un equilibrio entre sencillez, espontaneidad y distinción.

*Christian Dior*

L'élégance doit être un équilibre de simplicité, de naturel et de distinction.

*Christian Dior*

Elegance is a balance between simplicity, spontaneity and distinction.

*Christian Dior*

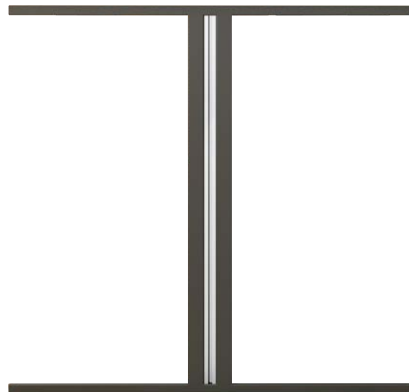

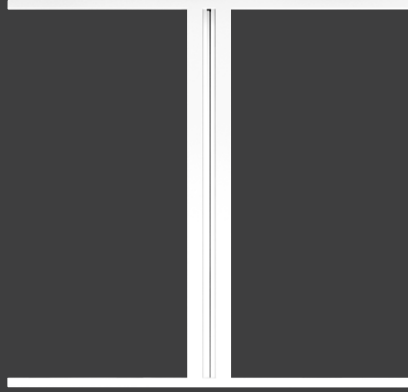

Elegance is a balance between simplicity,  
spontaneity and distinction.  
*Christian Dior*

L'élégance doit être un équilibre de  
simplicité, de naturel et de distinction.  
*Christian Dior*

La elegancia es un equilibrio entre  
sencillez, espontaneidad y distinción.  
*Christian Dior*



# Balance

Creating





Módulos suspendidos HS de archivo "High Storage" abiertos o cerrados que se adaptan a cada estilo de organización personal.

Modules de classement de grande capacité "High Storage" pour dossiers suspendus, ouverts ou fermés, adaptables à tous les types d'organisation.

Suspended "High Storage" HS filing modules, with our without doors, that adapt to every personal organisation style.











---

Nueva solución WS de archivo "Wing Storage" que permite optimizar la superficie de archivo como un espacio de trabajo.

Nouvelle solution de classement "Wing Storage" pour une optimisation de l'espace disponible à la surface du meuble, utilisable comme espace de travail

New "Wing Storage" WS filing solution that optimises filing area as work space.





Art of

# Harmony

---

La simplicidad y la armonía  
son la máxima sofisticación.  
*Leonardo Da Vinci.*

La simplicité et l'harmonie  
sont la sophistication suprême.  
*Leonardo Da Vinci.*

Simplicity and harmony  
are the ultimate refinement.  
*Leonardo Da Vinci.*

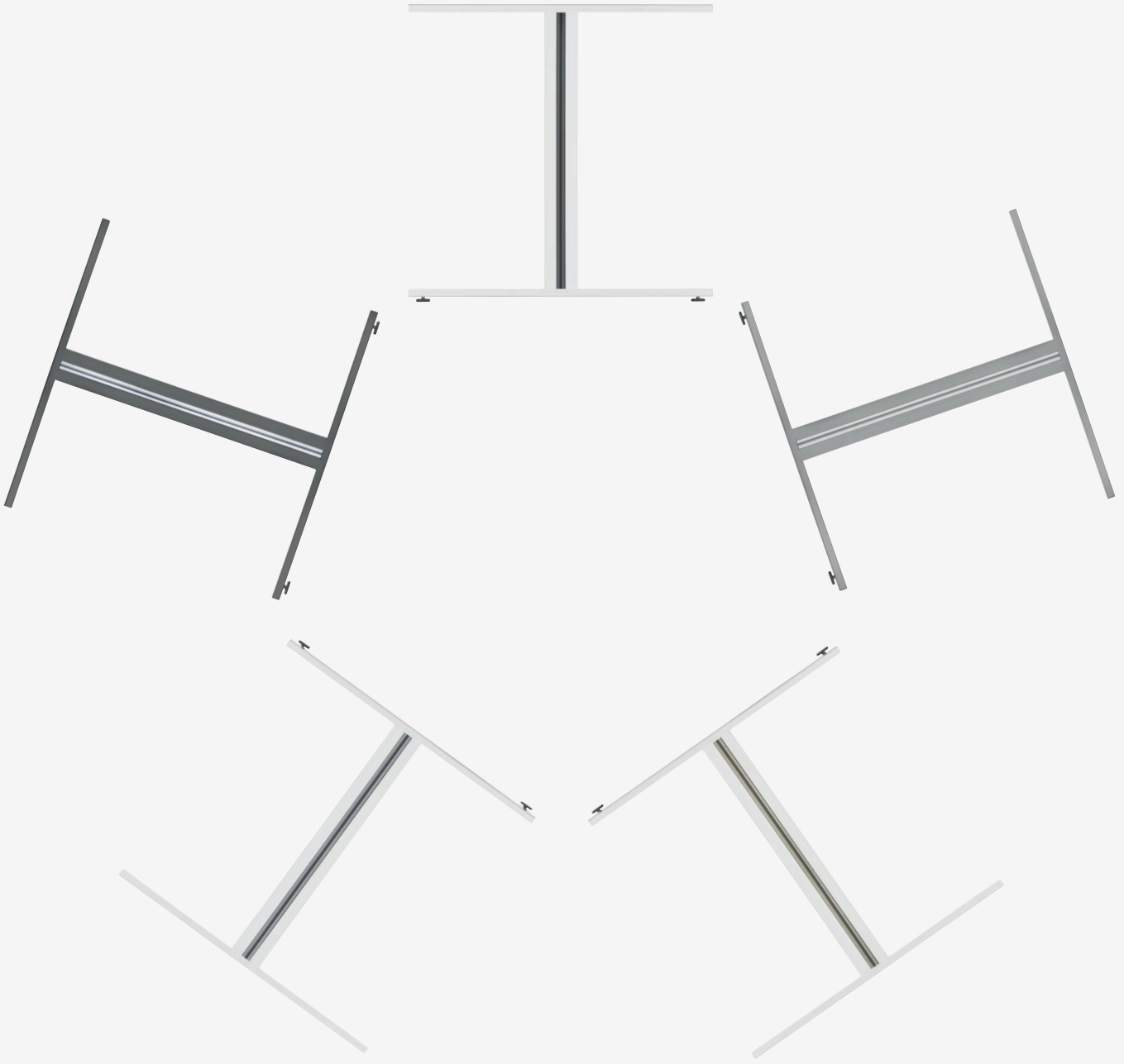

La combinación de TWork con el Módulo auxiliar operativo "MAO", permite crear espacios de trabajo semidireccionales.

L'association de TWork avec le module auxiliaire opérationnel "MAO" permet de créer des espaces adaptés à des postes de semi-direction.

Combining TWork with the auxiliary module "MAO" lets you create semi-executive work spaces.















El programa se completa con mesas de reuniones que combinan en acabados con otros puestos de trabajo o soluciones para el archivo.

Des tables de réunion viennent compléter ce programme. Leurs finitions s'harmonisent avec celles d'autres postes de travail ou d'autres solutions de classement.

The programme is complete with meeting tables that combine their finishes with other work desks or filing solutions.



# Highly Stable

---

Doble viga estructural.  
Double poutre structurale.  
Double structural beam.

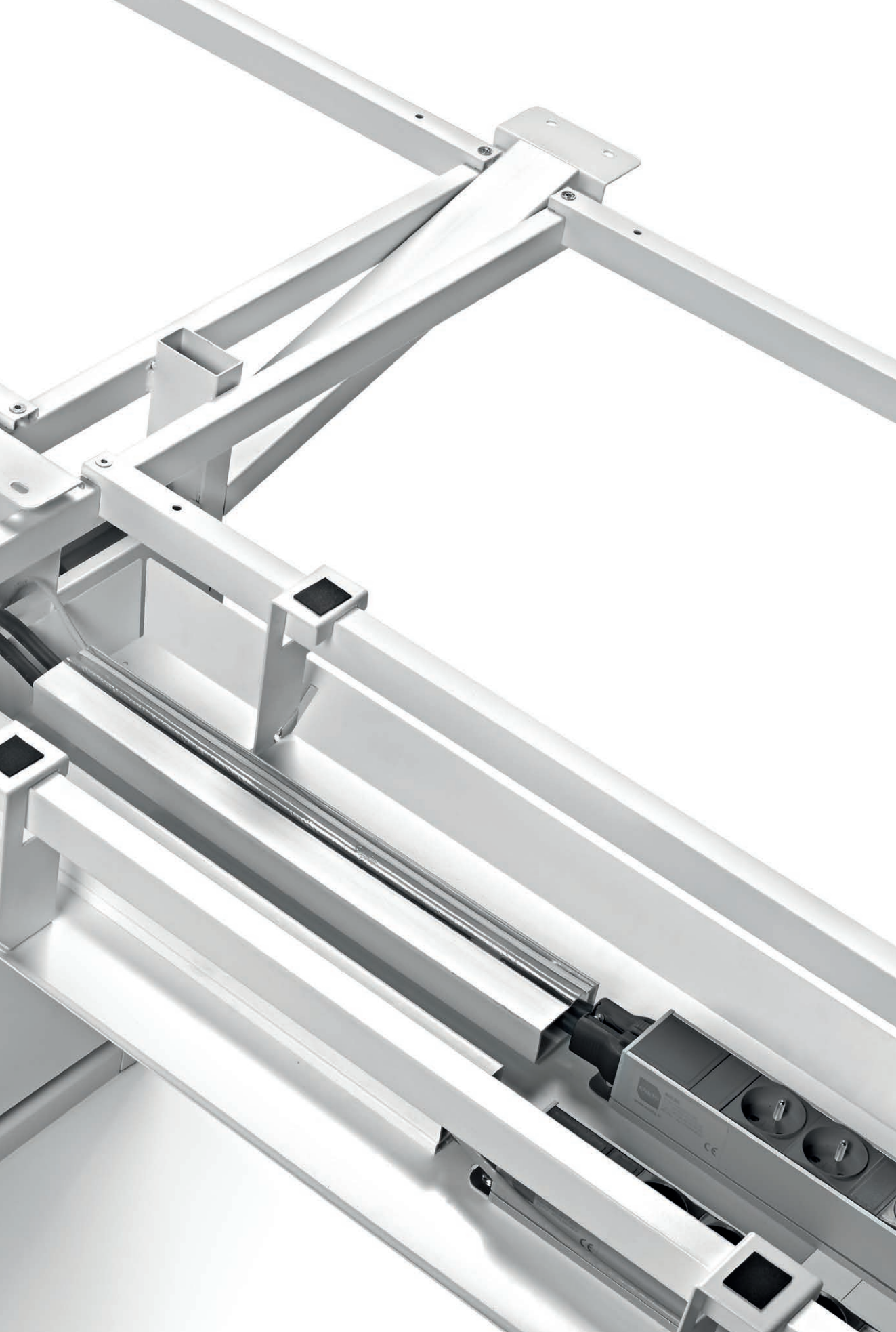

La serie hereda la doble viga desarrollada para Adapta Plus, que garantiza una excelente estabilidad.

La gamme hérite de la double poutre développée pour Adapta Plus garantissant une excellente stabilité.

The series inherits the double beam developed for Adapta Plus, which guarantees excellent stability.

# Is this **your problem?**

Inaccesibilidad  
Inaccessible  
Inaccessible

Falta de espacio  
Manque d'espace  
Lack of space

Desorden  
Désordre  
Disorder

Mal uso  
Mauvais usage  
Misuse

Incomodidad  
Mal a l'aise  
Uncomfortable

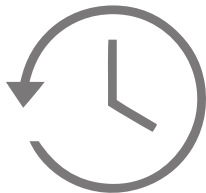

Pérdida de tiempo  
Perte de temps  
Waste time



Menor eficiencia  
Moins d'efficacité  
Less efficiency



Cansancio  
Fatigue  
Fatigue



# These are **our solutions...**

"WS" Wing Storage



"HS" High Storage

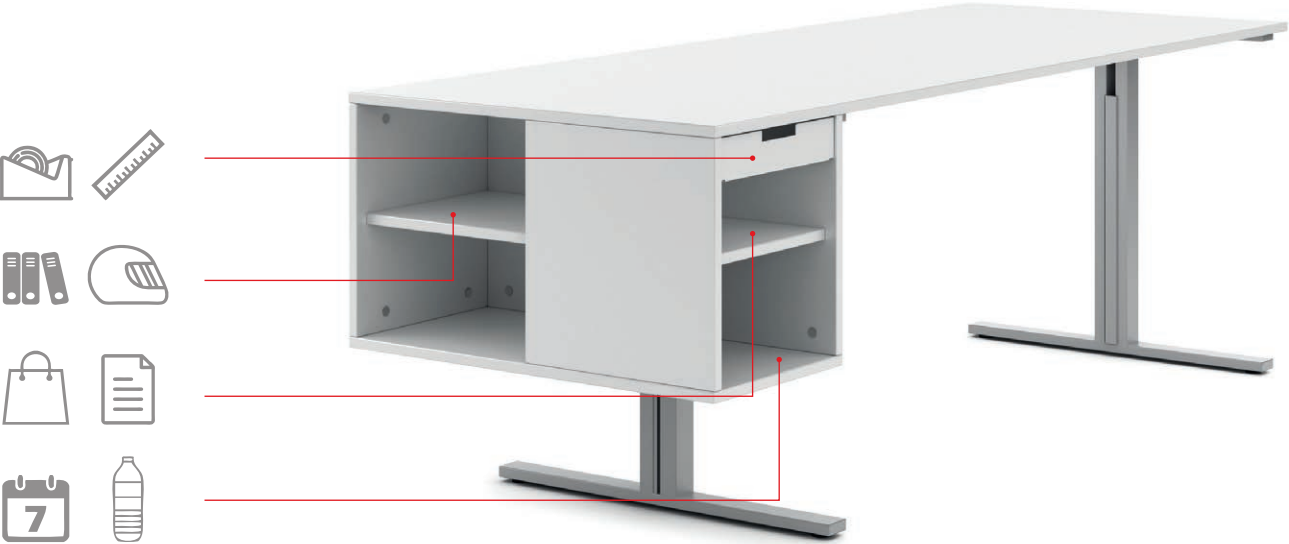

# Wing Storage

Módulo WS  
Module WS  
WS Module



Módulo extraíble de estantes y cajones, que aporta mayor superficie de trabajo y organización de los objetos personales necesarios en el día a día. El sistema permite la apertura y cierre con llave, facilitando la privacidad.

Module amovible d'étagères et caissons pour une surface de travail plus grande et une meilleure organisation du matériel de travail personnel. Muni d'une fermeture à clé. Confidentialité garantie.

Removable module with shelves and drawers, which adds more work space and storage capacity for day to day personal items. The module can be locked for greater privacy.



Switch ON / Switch OFF



# High Storage

---

Módulo HS  
Module HS  
HS Module



Módulo suspendido, nuevas soluciones de archivo personal incorporadas al puesto de trabajo que ofrece múltiples combinaciones de organización.

Module suspendu. Nouvelles solutions de classement personnalisées intégrées au poste de travail avec de multiples possibilités d'organisation.

Suspended module, new personal filing solutions integrated in the workstation that offers many organisation possibilities.

## Useful and Current

---

El módulo HS ha sido diseñado de acuerdo a las tendencias actuales como una única pieza, totalmente integrada en la superficie de trabajo que le confiere un aspecto visual muy compacto.

S'inscrivant dans la lignée des tendances actuelles, le module HS est d'un seul tenant, totalement intégré dans la surface de travail, ce qui lui confère un visuel très compact.

The HS module has been designed according to current trends as a single unit, fully integrated in the work surface for a visually compact appearance.



# Accessories

Cada cosa en su lugar  
Chaque chose à sa place  
Everything in the right place



## Order and Harmony

---

Nueva línea de accesorios que permite tener a mano todos los elementos de trabajo, facilitando el acceso y la conectividad. Su diseño y selección de materiales ha sido concebido para aportar mayor confort en su uso diario.

Nouvelle ligne d'accessoires permettant d'avoir tout votre matériel à portée de la main. Facilité d'accès et de connexion. Le design et le choix des matériaux vous procureront aisance et confort.

New range of accessories that keep work items handy, facilitating access and connectivity. Their design and material selection are intended to provide greater comfort in everyday use.



# Techline

---

Función y estilo  
Fonction et style  
Function and style

Perfil mecanizado disponible en 5 colores que permite fijar accesorios a la pata.  
Techline incorpora en su interior un sistema de canalización de voz y datos, pensado para electrificar de forma óptima el puesto de trabajo. Esta pieza singular protagoniza la personalidad de la serie y le confiere una estética diferente.

Profilé usiné disponible en 5 couleurs permettant de fixer les accessoires au pied.  
Techline contient un système de câblage (communication vocale et transmission des données) pour une électrification optimale des postes de travail. Cet élément singulier dote la gamme de toute sa personnalité et d'une esthétique atypique.

Machined profile available in 5 colours that enables accessories to be attached to the leg.  
Techline incorporates a channel for voice and data inside for the optimal electrification of the workstation. This exceptional piece highlights the personality of the series and gives it a unique look.

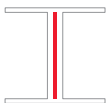



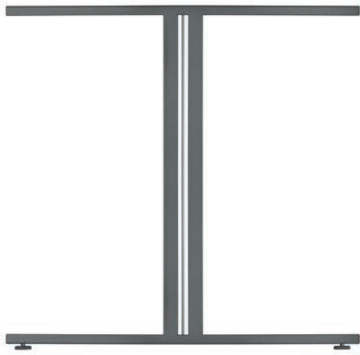

B3



B3



B3



CH



CH



CH



CR



AT



AT



TI



TI



TI

# Electrification

Soluciones de electrificación  
Solutions d'électrification  
Wire management solutions



Canal flexible integrado en todas las patas finales para la correcta separación de cable eléctrico y voz-datos.

Circuit souple intégré dans tous les pieds placés aux extrémités pour une séparation correcte des câbles de communication vocale et de transmission des données.

Flexible integrated channel in all rear legs for the correct separation of electric cable and voice-data.



Solución estándar TWork, de pata intermedia electrificable para la creación de mesas multipuesto.

Solution standard TWork, pied intermédiaire électrifiable pour la création de tables multipostes.

Standard TWork solution, intermediate leg that can be cabled, for creating multi-user desks.



Pata panelada electrificable Adapta Plus compatible con la serie TWork.

Pied-panneau électrifié Adapta Plus, compatible avec la gamme TWork.

Adapta Plus panelled leg that can be cabled, compatible with the TWork series.



Las patas y vigas del programa TWork, son electrificables por su interior, con separación para voz-datos y cableado eléctrico. Todas las patas disponen del sistema de electrificación convencional y están adaptadas para la compatibilidad con suelo técnico.

Les pieds et les poutres du programme TWork sont électrifiés de l'intérieur. Séparation entre les câbles de communication vocale-transmission des données et les câbles électriques.

Tous les pieds disposent d'un système de câblage conventionnel et sont compatibles avec les planchers techniques.

The legs and beams of the TWork series can be cabled inside, with separation for voice-data and electric cables. All the legs feature the conventional electrification system and are adapted for raised technical floor compatibility.

## Accessible and **Versatile**

---

Bandeja y canalizaciones pasacables que facilitan el acceso eléctrico y voz-datos mediante el "top acces".

Una solución adaptada a la longitud total de la mesa que permite el orden y limpieza en el cableado.

Plateau et passe-câbles facilitant l'installation des fils électriques et des câbles de communication vocale-transmission de données. Système "top access".

Une solution adaptée à la longueur totale de la table permettant de maintenir l'ordre et la propreté du câblage.

Tray and cable grommets for easy access to sockets and voice-data with "top access".

This solution adapts to the entire length of the desk to keep cables neatly out of the way.





Accesorio de sobremesa electrificable, removible y adaptable a todas nuestras bases de enchufe "Power Solutions", con salida inferior y lateral de cables. En su parte superior se encuentra integrada una bandeja con fieltro para depositar objetos. Esta solución esta preparada para fijarse al sobre de la mesa.



Accessoire de table électrifié, amovible et adapté à toutes nos prises électriques "Power Solutions" avec sortie inférieure et latérale des câbles. La partie supérieure est munie d'un plateau-vidé-poche recouvert de feutre. Cet accessoire est destiné à être fixé sur le plateau de la table.

Desktop power supply accessory, removable and adaptable to all our "Power Solutions" power sockets, with lower and side opening for cables. It features a felt-lined integrated storage tray on top. This solution can be mounted to the desk top.



Bandeja para Bench con sistema abatible para fácil acceso al cableado y conexiones.

Plateau pour bench avec système abattable facilitant l'accès au câblage et aux connexions.

Bench tray with flip system for easy access to wiring and connections.



Top access individual de apertura por un lado o de juntas con apertura por ambos.

Top Access table individuelle; ouverture d'un seul côté. Top Access table de réunion; ouverture des deux côtés.

Individual Top Access with single side opening, or for meeting table with opening on both sides.

**Melamine**  
Mélamine | Melamine

**R6** .....

**Roble 06**  
Chêne 06  
Oak 06



**H5** .....

**Haya 05**  
Hêtre 05  
Beech 05



**W6** .....

**Wengué 06**  
Wengué 06  
Wengué 06

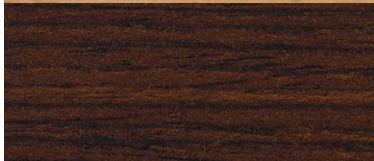

**B3** .....

**Blanco 9003**  
Blanc 9003  
White 9003



**NO** .....

**Nogal**  
Noyer  
Walnut



**DP** .....

**Dauphin**  
Dauphin  
Dauphin

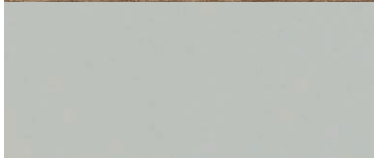

**A1** .....

**Arce 2011**  
Érable 2011  
Maple 2011



**AL** .....

**Aluminio**  
Aluminium  
Aluminium

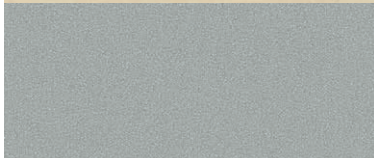

**TI** .....

**Titanio**  
Titane  
Titanium

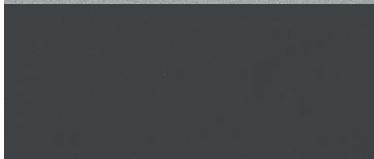

**NE** .....

**Negro**  
Noir  
Black



**Madera Barnizada**  
Placage Bois Verni | Wood Veneer

**MR6**

**Roble 06**  
Chêne 06  
Oak 06



**CE**

**Cerezo**  
Merisier  
Cherry



**MEB**

**Ébano**  
Ébène  
Ebony



**MGR**

**Gris Ceniza**  
Gris Cendre  
Ash Grey

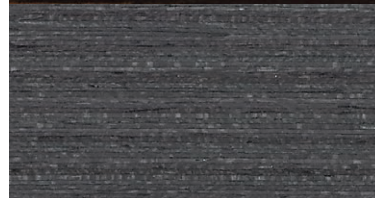

**MTE**

**Teca**  
Thèque  
Teak



**MW6**

**Wengué 06**  
Wengué 06  
Wengué 06



**HA**

**Haya**  
Hêtre  
Beech



**MC9**

**Arce 2009**  
Érable 2009  
Maple 2009

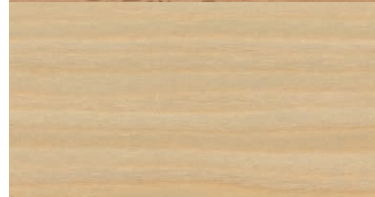



**Metal Époxy**  
Métal Epoxy | Epoxy Metal

**B3**

**Blanco Ral 9003**  
Blanc Ral 9003  
White Ral 9003

**AT**

**Aluminio Texturado**  
Aluminium Texturé  
Textured Aluminium

**TI**

**Titanio**  
Titan  
Titanium

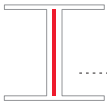
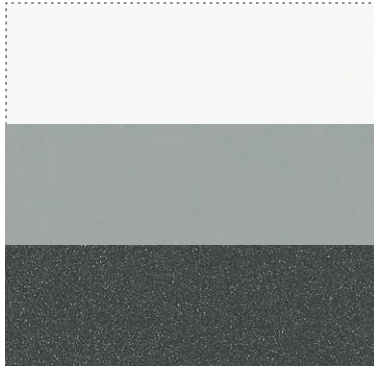

**Techline**

**B3**

**Blanco Ral 9003**  
Blanc Ral 9003  
White Ral 9003

**AT**

**Aluminio Texturado**  
Aluminium Texturé  
Textured Aluminium

**TI**

**Titanio**  
Titan  
Titanium

**CH**

**Champagne**  
Champagne  
Champagne

**CM**

**Cromo**  
Chrome  
Chromium

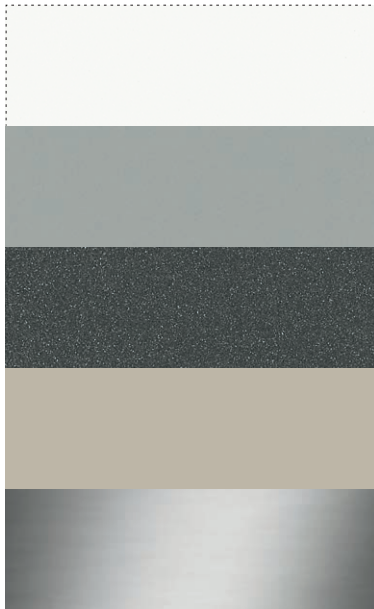

**Metacrilato**  
Methacrylate | Plexiglass

**BN**

**Blanco nieve**  
Blanc neige  
White snow

**AZ**

**Azul**  
Bleu  
Blue

**GR**

**Gris**  
Gris  
Grey

**VE**

**Verde**  
Vert  
Green

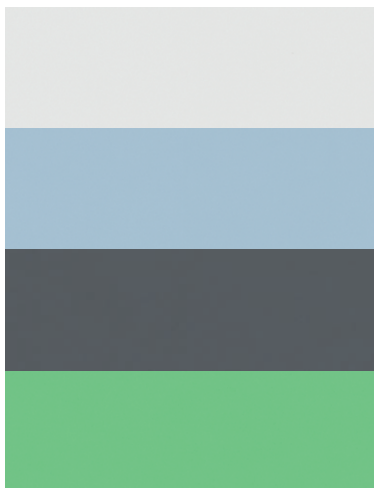

**S-One Slim**  
Tapizados | Tissus | Upholstery



**494**

**Gris**  
Gris  
Grey

**452**

**Azul**  
Bleu  
Blue

**432**

**Violeta**  
Violet  
Violet

**446**

**Verde**  
Vert  
Green

**474**

**Naranja Arizona**  
Orange Arizona  
Arizona Orange

**S-Two Duo**  
Tapizados | Tissus | Upholstery



**202**

**Gris**  
Gris  
Grey

**225**

**Azul**  
Bleu  
Blue

**219**

**Fucsia**  
Fuchsia  
Fuchsia

**234**

**Verde Oliva**  
Vert Olive  
Olive Green

**239**

**Naranja Arizona**  
Orange Arizona  
Arizona Orange

Los colores y materiales representados en dicha publicación pueden diferir ligeramente de la realidad debido a los límites de impresión.

Les coloris et les matériaux peuvent différer légèrement de la réalité du aux limitations du système d'impression.

Colours and materials displayed in this brochure can differ slightly from reality due to the printing limitations.

Mesas | Tables | Tables

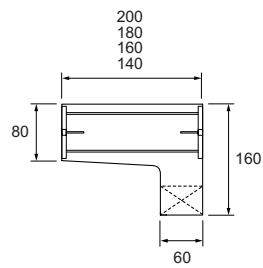
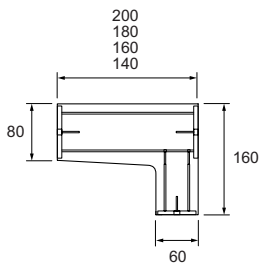
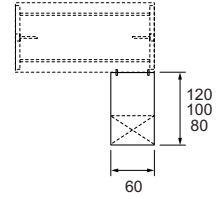
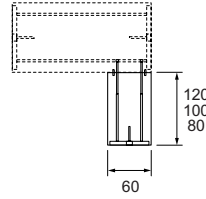
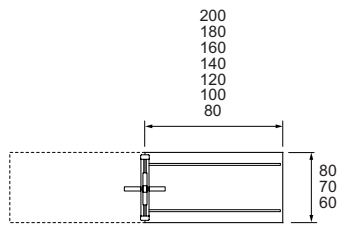
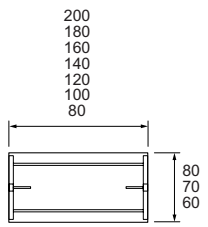

JG Group  
60  
TWork

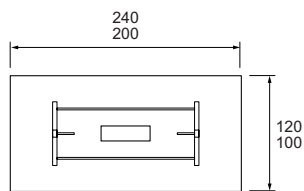
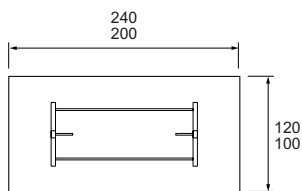
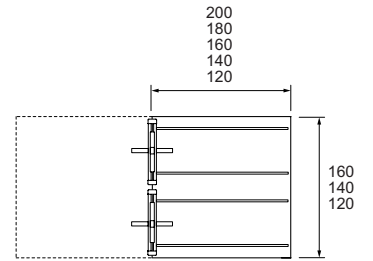
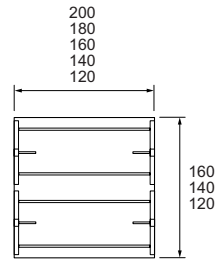
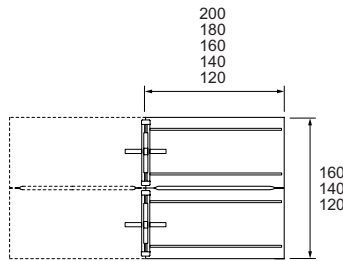
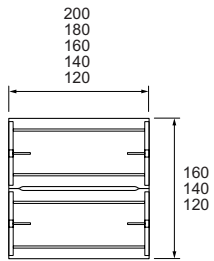



WS - Wing Storage

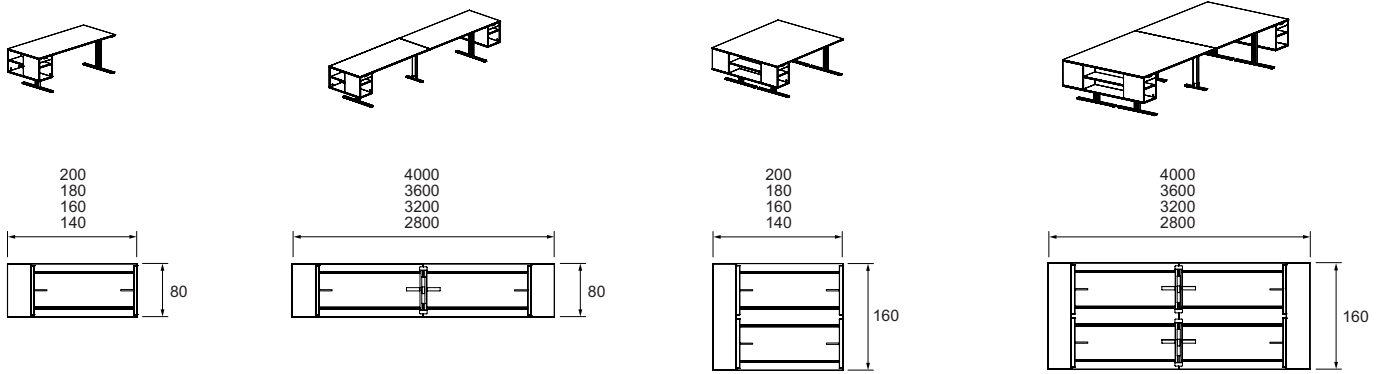

HS - High Storage

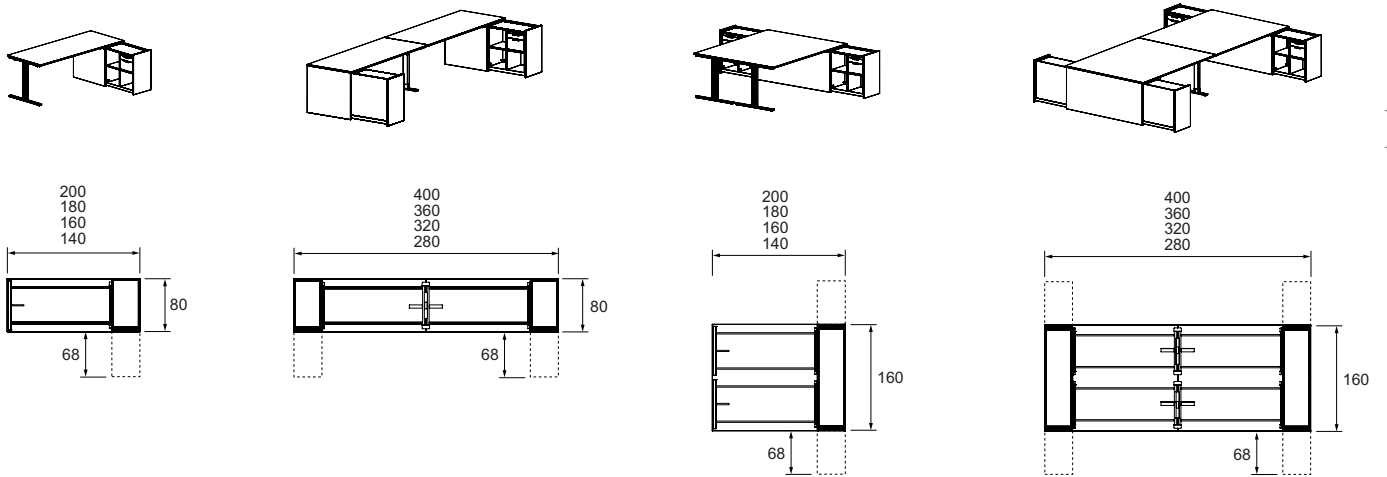

Patas | Piedements | Legs

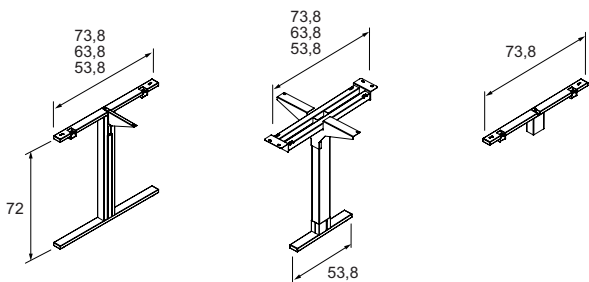

MAO

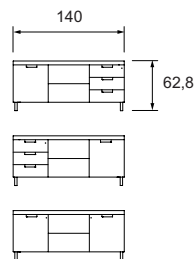

Qbuc

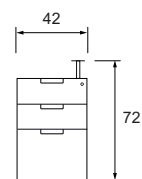

CP

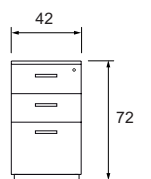

# Quality and Ecology

Disponemos desde hace años de la certificación de calidad **ISO 9001** y del sello **TECNALIA**, entidad que verifica y homologa las materias primas y el cumplimiento de las diferentes normativas europeas aplicables al mobiliario de oficina.

En política de respeto al medioambiente, hemos implementado y certificado todas las medidas recogidas en las normas **ISO 14001** e **ISO 14006**, y también ofrece bajo demanda la certificación forestal de la cadena de custodia por los sistemas **PEFC** y **FSC®**, garantizando que la madera utilizada procede de una gestión forestal sostenible.

El cumplimiento de todas estas normas facilita la obtención de puntos **LEED** con nuestros productos.

Notre société dispose depuis plusieurs années, du certificat de qualité **ISO 9001**, et du label **TECNALIA**, entité qui vérifie et homologue les matières premières, et certifie la conformité aux différentes normes européennes applicables au mobilier de bureau.

En ce qui concerne notre politique de respect pour l'environnement, nous avons implanté et certifié toutes les directives recueillies dans les normes **ISO 14001** et **ISO 14006**, et offre aussi sous demande du client, la certification forestière selon système **PEFC** et **FSC®**, en garantissant que la matière utilisée provient d'exploitations à bois soutenables.

La conformité à toutes ces normes, facilite l'obtention de points **LEED** avec nos produits.

Our company has the quality certification **ISO 9001** and **TECNALIA** for years, institution that verifies and standardizes raw material and compliance with European norms applicable to office furniture.

Regarding to environmental policy, our company has implemented and certified all the measures contained in the **ISO 14001** and **ISO 14006**, and also supplies by demand the forest certification of chain of custody for **PEFC** and **FSC®** systems, ensuring that the wood used comes from sustainable forest management.

Compliance with these standards facilitates obtaining **LEED** points with our products.

