

Gaber®

2013





MORE

Favaretto&Partners / info pag. 348



Piu' e ancora di Piu'... Una sedia importante che fosse da outdoor ma anche indoor versatile, elegante, importante ma assolutamente unica. Nasce così "More", una monoscocca in polipropilene che si presta ad essere rivestita interamente o, e qui sta la sua innovazione, solo con una sorta di cuscino fissato alla scocca mediante 9 bottoni pensati e realizzati ad hoc, in materiale plastico. Questa versione sicuramente innovativa per la sua facilità di trasformazione è stata pensata per rendere "More" adatta sia ad ambienti esterni che interni, grazie proprio all'applicazione, mediante una semplice ed elementare operazione, di questo pratico rivestimento. Le strutture di sostegno sono sei: 4 gambe in metallo cromato o verniciato, 4 gambe in legno, traliccio in tondino di acciaio, base girevole a 4 razze e la versione a 5 razze con ruote ed in fine su barra.

More and ever more... one important chair for outdoor and indoor useful, elegant, important but unique. In this way born "More", one shell in techno polymer that is likely to be covered entirely or, and here is its innovation, only a sort of cushion attached to the body through 9 buttons designed and implemented ad hoc. This version certainly innovative for its ease of processing has been designed to make it "more" suitable for both indoor and outdoor, with their application, using a simple and basic operation of this practical covering. The support structures are six: four legs in chromed or painted, 4 legs in wood, one special metal frame, 4 star swivel base and version 5-spoke wheels base and at the end the solution of the bench.



MORE

Favaretto&Partners

info pag. 348

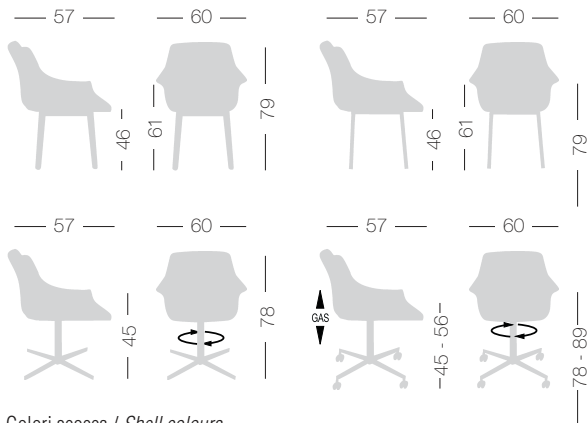

Colori scocca / Shell colours

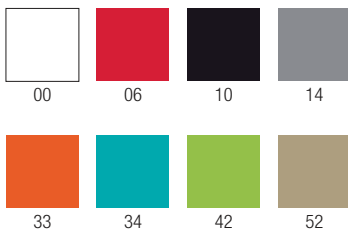

Colori tessuto King (imbottiture e cuscini)

King fabric colours (upholstered versions and cushions)



Colori Ecopelle Aurea (imbottiture e cuscini)

Aurea skai colours (upholstered versions and cushions)

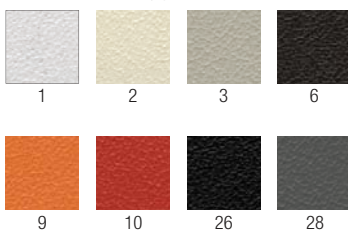

Piu' e ancora di Piu'... Una sedia importante che fosse da outdoor ma anche indoor versatile, elegante, importante ma assolutamente unica.

Nasce così "More", una monoscocca in polipropilene che si presta ad essere rivestita interamente o, e qui sta la sua innovazione, solo con una sorta di cuscino fissato alla scocca mediante 9 bottoni pensati e realizzati ad hoc, in materiale plastico.

Questa versione sicuramente innovativa per la sua facilità di trasformazione è stata pensata per rendere "More" adatta sia ad ambienti esterni che interni, grazie proprio all'applicazione, mediante una semplice ed elementare operazione, di questo pratico rivestimento.

Le strutture di sostegno sono sei: 4 gambe in metallo cromato o verniciato, 4 gambe in legno, base girevole a 4 razze e la versione a 5 razze con ruote ed in fine su barra.

More and ever more... one important chair for outdoor and indoor useful, elegant, important but unique.

In this way born "More", one shell in techno polymer that is likely to be covered entirely or, and here is its innovation, only a sort of cushion attached to the body through 9 buttons designed and implemented ad hoc.

This version certainly innovative for its ease of processing has been designed to make it "more" suitable for both indoor and outdoor, with their application, using a simple and basic operation of this practical covering.

The support structures are six: four legs in chromed or painted, 4 legs in wood, 4 star swivel base and version 5-spoke wheels base and at the end the solution of the bench.





SLOT

Favaretto&Partners / info pag. 352



SLOT

Favaretto&Partners

info pag. 352

Slot significa fessura, apertura, taglio.

E' proprio dal taglio sullo schienale che questa sedia prende il suo nome.

Impilabile, versatile, maneggevole, elegante e raffinata, è adatta a molteplici luoghi con esigenze e caratteristiche molto diverse, dal contract all'ufficio agli ambienti domestici.

Il prodotto è composto da una monoscocca in polipropilene, disponibile in molteplici colorazioni, con inserto in polycarbonato trasparente.

La struttura di sostegno in metallo cromato o verniciato è proposta in diverse varianti: 4 gambe con o senza bracciolo, slitta con o senza bracciolo, base girevole con e senza ruote oppure su barra.

L'innovazione ergonomica funzionale è data proprio dal taglio sullo schienale. Infatti, flettendo la parte alta dello stesso, bascula ed avanza automaticamente la parte bassa, supportando così maggiormente la zona lombare dando un grande comfort molto apprezzabile.

Slot mean cutting, opening... It is just cut back on this chair takes its name.

Stackable, useful, handy, elegant and refined, is suitable for many places with very different characteristics and needs, from contract office as homes.

The product is composed of a shell in polypropylene, available in various colors, with transparent polycarbonate inserts.

The support structure in chromed or painted metal comes in different variants: 4 legs with or without armrests, slide with or without armrests, swivel base with or without castors or on bench.

The innovative ergonomic functional is given just cut on the back. In fact, bending the upper part of the same, and automatically advances the rocker bottom, thus supporting further the lumbar giving a great comfort that is much appreciated.

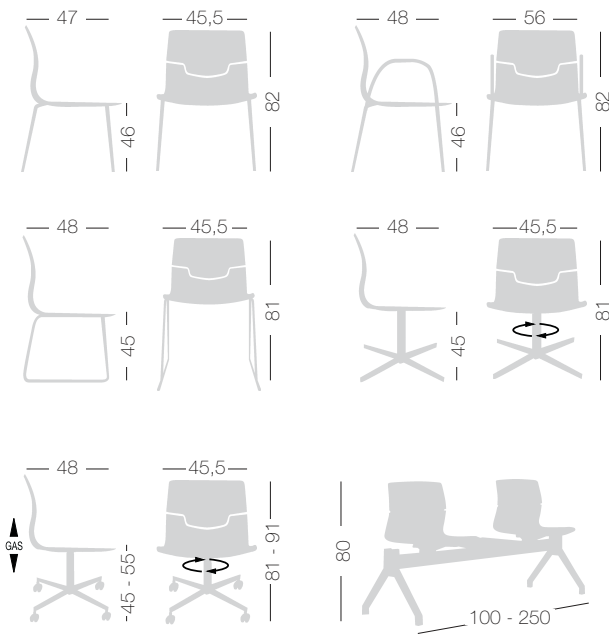

Colori scocca / Shell colours

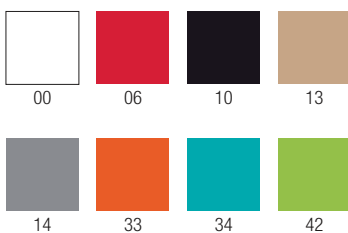

SLOT

Favaretto&Partners / info pag. 352



PANAMA

Stefano Sandonà / info pag. 350

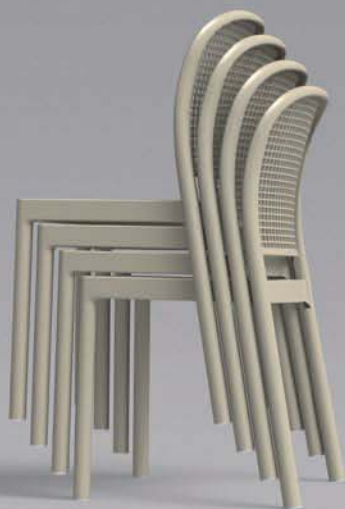



PANAMA

Stefano Sandonà

info pag. 350

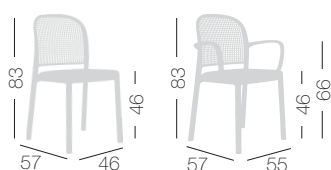

Colori scocca / *Shell colours*

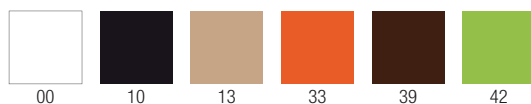

Colori ecopelle Aurea / *Aurea skai colours*

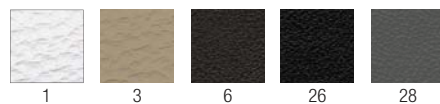

Colori tessuto King / *King fabric colours*

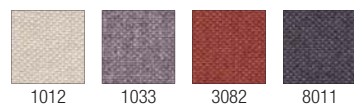

Innovazione tecnologica e grande ricerca nell'utilizzo dei materiali danno vita a questa sedia dalle linee morbide ed attuali.

The chair was born from technological research and experimentation in the use of materials. The soft and actual lines countersign its design.



BLOG

Stefano Sandonà / info pag. 340





BLOG

Stefano Sandonà

info pag. 340

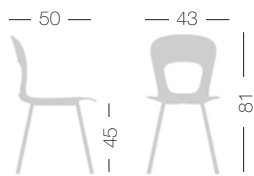
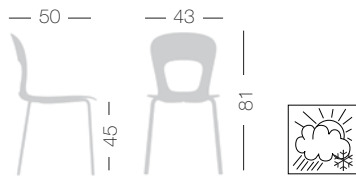
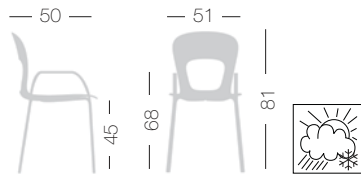

Colori scocca / Shell colours

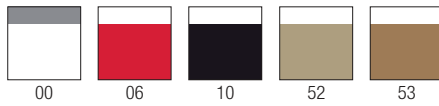

Colori pelle (imbottiture) / Leather colours (upholstered versions)

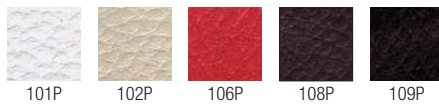

Un'allusione alla finestra di messaggi dei diari online, Blog unisce la dolcezza della forma alla leggerezza della struttura per far sorgere una sedia pratica e giovanile.

An allusion to the message window of the diaries online, Blog combines the sweetness of the form to the lightness of the structure to give rise to a chair practical and youthful.





CLAIRE

Stefano Sandonà

info pag. 340

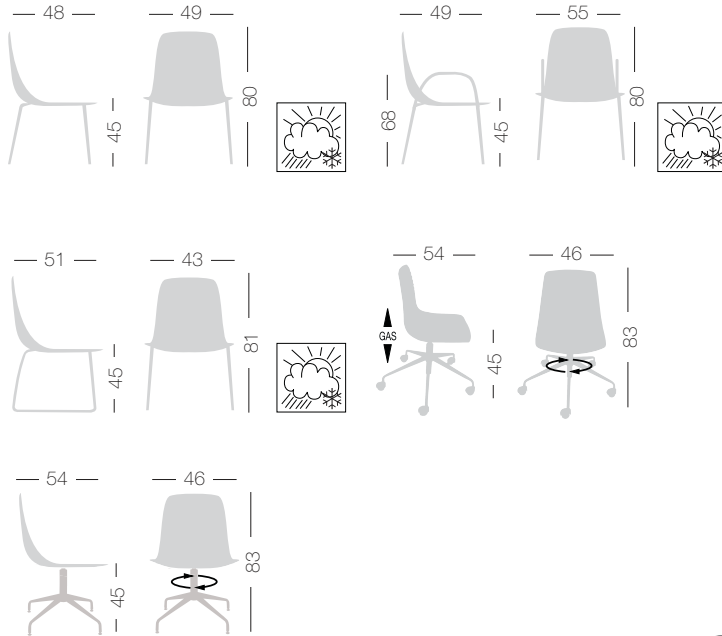

Colori brillanti e pastello, gradazioni cromatiche del grigio, del verde, del marrone esprimono i colori della natura. Con il suo stile prêt à porter, e le varie colorazioni a disposizione si abbina perfettamente a qualsiasi ambiente indoor/outdoor rendendolo elegante e alla moda. Realizzata integralmente in tecnopolimero, con telaio a quattro gambe in metallo verniciato o cromato.

With bright colours and crayon, chromatic gradations of the grey one, of the green and of the brown one express the colours of the nature. With his style prêt à porter, and the various colours available, matches perfectly to all indoor/outdoor places making elegant and fashion. Made entirely of techno-polymer, with a frame with four legs in painted or chromed metal.

Colori scocca / Shell colours

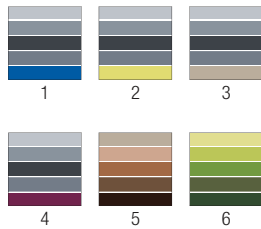



MOEMA

Stefano Sandonà

info pag. 346

Sedia composta da una scocca in tecnopolimero o imbottita in pelle, fissata ad un telaio in metallo cromato per uso in location interne, con l'opzione di poterla montare su di un telaio trattato e verniciato per l'uso in ambienti esterni. Impilabile.

Chair composed by a techno polymer shell or leather covering, assembled with a chromed metal frame for the indoor location or with a painted frame for the outdoor places. Stackable.

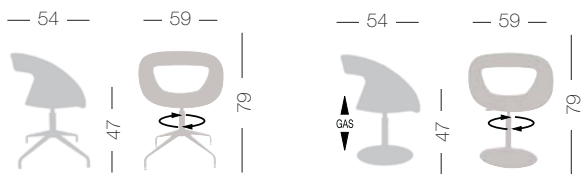
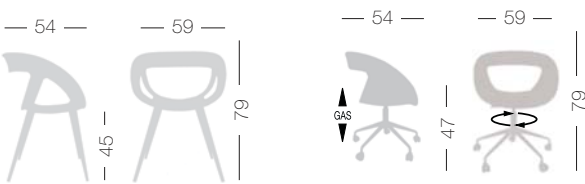
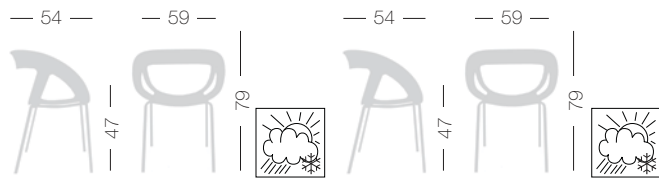

Colori scocca / Shell colours

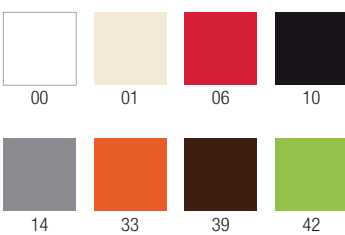





MOEMA

Stefano Sandonà

info pag. 364

Sedia composta da una scocca in tecnopolimero o imbottita in pelle, fissata ad un telaio in metallo cromato per uso in location interne, con l'opzione di poterla montare su di un telaio trattato e verniciato per l'uso in ambienti esterni. Impilabile.

Chair composed by a techno polymer shell or leather covering, assembled with a chromed metal frame for the indoor location or with a painted frame for the outdoor places. Stackable.



Colori pelle / Leather colours



101P 102P



106P 108P



109P 110P



ALHAMBRA

Stefano Sandonà

info pag. 338

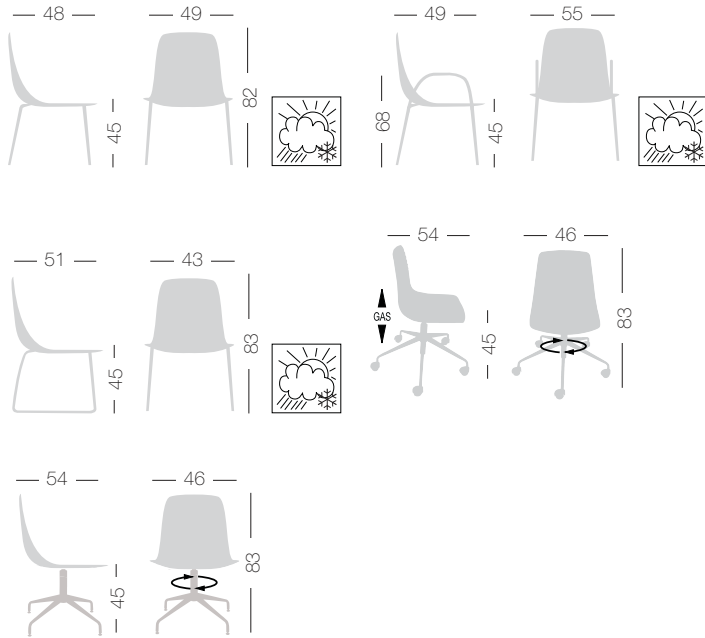

Colori scocca / Shell colours

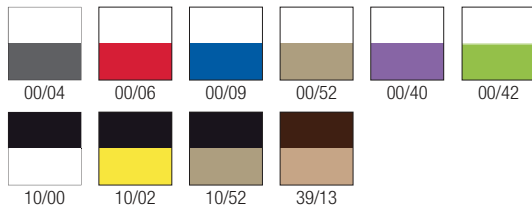

Lo stile unico e l'armonia della tessitura geometrica che ne disegna le superfici, rende ALHAMBRA una sedia con una forte personalità ed un inconfondibile senso estetico della forma, grazie anche allo sviluppo ed applicazione di un innovativo sistema di produzione brevettato. ALHAMBRA è realizzata con una seduta in tecnopolimero multicolor montata su telaio in metallo cromato, verniciato colore bianco e diversi basamenti. E' disponibile anche nella versione rivestita.

The unique style and the harmony of the geometric weaving that it draws the surfaces of it, make ALHAMBRA a chair with a strong personality and an unmistakable aesthetic sense of the form, thanks also to the development and application of an innovative system of production patented. ALHAMBRA is realized with a seat in multicolor techno polymer with in chromed or painted white color metal fame and different based. It is available also in the upholstered version.

interior
innovation
award
2010
nominated

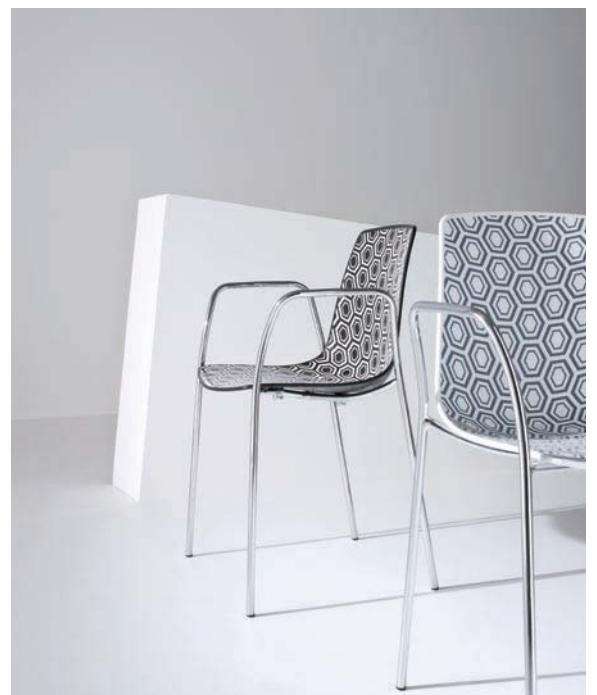





LUN 3 12
MER 5 7



ALHAMBRA-ECO

Stefano Sandonà

info pag. 339

Oggi giorno stiamo assistendo ad un importante innalzamento dell'attenzione nei confronti dei prodotti eco-friendly. Le aziende produttrici si impegnano a ricercare nuovi sistemi di produzione che, almeno in parte, riescano a riutilizzare tutti quel materiale che nei processi standard di produzione va sprecato. Anche in questo, Gaber dimostra di essere assolutamente al passo con i tempi, sviluppando una versione "ecologica" della sedia Alhambra. Questa è composta da due unità distinte che successivamente vengono assemblate per dare corpo ad un unico oggetto dal design quanto mai piacevole ed attuale.

La prima parte è la scocca, stampata ad iniezione, addirittura in due colori contemporaneamente, con l'utilizzo di materiale plastico riciclato e segatura di legno, anch'essa ovviamente ricavata da scarti di produzione. Il particolare sistema di stampaggio permette di fondere assieme i due componenti dando vita ad una miscela che, una volta raffreddata, si irrigidisce al punto da creare una struttura molto resistente e dalla finitura semilucida nella quale si possono distinguere i diversi componenti.

La seconda parte invece è il telaio. Anche questo stampato ad iniezione ma con l'ausilio di componenti differenti, un polimero riciclato ad alte prestazioni e il legno sottoforma di impasto. Anche in questo caso i due materiali si fondono assieme in una miscela omogenea nella quale i componenti sono indistinguibili. La struttura risulta essere estremamente resistente e dalle linee incredibilmente esili.

Il risultato, frutto di ingenti investimenti nella ricerca dei materiali e in nuove tecnologie per lo stampaggio delle materie plastiche, è entusiasmante, soprattutto rivolgendo l'attenzione alla enorme quantità di materiale che si può riutilizzare in questo tipo di ciclo produttivo.

Nowadays there's a big attention to eco-friendly products. Manufacturer companies search new production systems that can reuse all material which is wasted during standard ones.

For this reason, Gaber company demonstrates to be current and renewed offering a new "ecological" version of Alhambra chair.

This chair is composed of two units that can be assembled to give shape to an unique pleasant and contemporary design object.

The first unit is the shell injection molded in two different colours.

It is obtained using recycled plastic material and sawdust got from production waste. This particular injection system melts down together the two components and generates a mixture which stiffens, when it becomes colder, and takes the form of a very resistant structure with a semi-gloss finish.

The second unit, instead, is the frame injection molded too, using two different components: high performance recycled polymer and wood like dough. Also these materials blend together in a homogeneous mixture in which they're indistinguishable. The result is a very strong frame with thin lines.

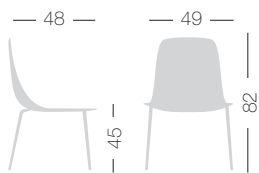

Colori scocca / Shell colours



39/13



L'eleganza e la visione contemporanea delle forme, rendono ANITA una sedia dalle linee morbide e accoglienti, una sintesi raffinata del nuovo classico. ANITA è una seduta realizzata integralmente in tecnopolimero. È impilabile e disponibile nei colori bianco, rosso e nero. Disponibile anche nella versione imbottita.

The elegance and the contemporary vision of the forms, make ANITA a chair with the soft and pleasant lines, a refined synthesis of the new classical. ANITA is a seat integrally realized in technopolymer. It is stackable and it is available in the colors white, red and black. Available also in the upholstered version.



ANITA

Stefano Sandonà

info pag. 339

Colori cuscino / *Cushion colours*





BIG BANG

Stefano Sandonà e Sabrina Bettini

info pag. 339

BIG BANG è una sedia che usa il linguaggio digitale per dare vita ad un'esplosione di colori e alla decostruzione formale della sedia tradizionale. La fusione del suo interno mette in evidenza i suoi strati compositivi rendendoli parte integrante del design. Una soluzione grafica innovativa grazie anche allo sviluppo e all'applicazione di un innovativo sistema di produzione brevettato. BIG BANG è realizzata con una seduta in tecnopolimero multicolor e da un telaio in metallo cromato o verniciato colore bianco.

An innovative graphic solution thanks also to the development and application of an innovative system of production patented. BIG BANG is realized with a seat in multicolor techno polymer and a chromed or white painted metal frame.

**GOOD
DESIGN
AWARD
2010**

OF CHICAGO
ATHENAEUM :
MUSEUM OF
ARCHITECTURE
AND DESIGN

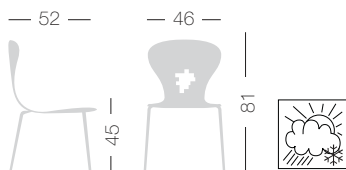

Colori scocca / Shell colours

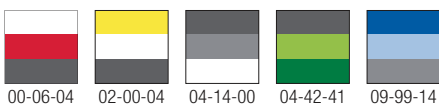

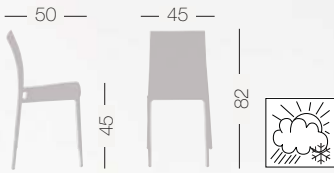

Colori scocca / Shell colours

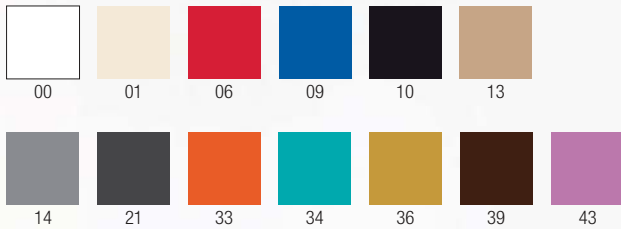

MOON

Studio Eurolinea

info pag. 347

Moon resiste alla fatica e non teme gli agenti atmosferici. E' una seduta adatta al mondo contract e agli ambienti residenziali. E' disponibile anche nelle versioni imbottite nei modelli Venezia e Parma.

Moon is resistant to fatigue and weather conditions. It is suitable for contract market and residential ambiances. It is also available in two padded versions: Venezia and Parma.



MAGIC

SO FUNCTIONAL: IT'S A KIND OF MAGIC

Studio Eurolinea / info pag. 346



OVER

WILL BRING YOU ALL OVER THE WORLD

Studio Eurolinea / info pag. 350



Colori scocca / Shell colours



00	01	03	04	06	09	10	14
21	22	33	34	36	38	39	40



La seduta e lo schienale in polipropilene poggiano su una struttura in tecnopolimero elastomero che garantisce linee estremamente sottili senza però intaccare resistenza e stabilità. È impilabile e disponibile in una vasta gamma di colori.

The polypropylene seat and back rest on a structure made of tecnopolimere elastomere which guarantees fine lines without prejudicing strength and stability. It is stackable and available in a large range of colours.

IRIS - IRIS B

Studio Eurolinea - info pag. 344





IRIS - IRIS B

Studio Eurolinea

info pag. 344

Sedia e poltroncina stampata
in tecnopolimero con struttura
in metallo sovrastampato.
Sedia adatta all'uso indoor
e outdoor.

Chair and armchair moulded
with technopolymer and metal
frame overmoulded with
technopolymer.
Indoor and outdoor use.

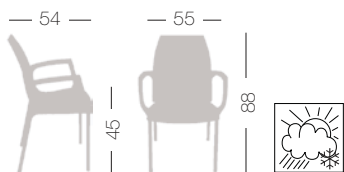
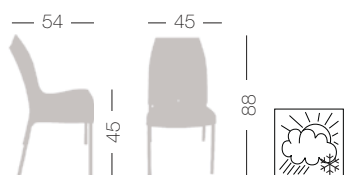

Colori scocca / Shell colours

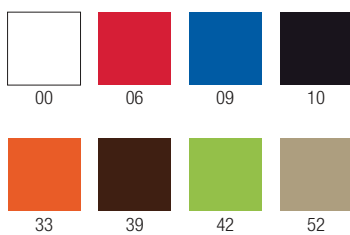

LIBERTY

Studio Eurolinea

info pag. 345

Liberty è una sedia studiata per comporsi in configurazioni aperte e flessibili. E' una seduta molto robusta e adatta agli utilizzi contract e residenziale, per l'uso all'esterno e all'interno. E' presente anche la versione imbottita Modena. Disponibile anche lo sgabello Liberty.

Liberty is a chair studied to settle open and flexible configurations. It's a very robust sitting, suitable for contract and residential use, for outdoor and indoor use. It's also available the padded version Modena. It is available the Liberty barstool.

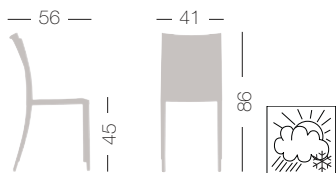

Colori sedia / Chair colours

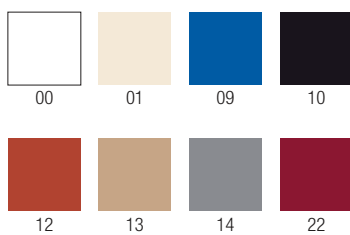



TEA

Studio Eurolinea

info pag. 354

Il Design originale , raffinato e la particolarità dell'intreccio garantiscono una perfetta versatilità d'uso del prodotto. Incredibilmente simile alla fibra naturale , non necessita di manutenzione periodica e garantisce ottime caratteristiche di resistenza agli agenti atmosferici. Questo modello è disponibile in 4 varianti colore.

The original Design, refined and the particularity of the interlacement they guarantee a perfect versatility of use of the product. Incredibly similar to the natural fiber, doesn't need periodic maintenance and guarantees good characteristics of resistance to the atmospheric agents. This model is available in 4 varying color.

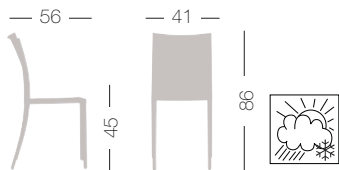

Colori sedia / Chair colours

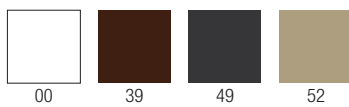



FLOWER

Laura Tombari

info pag. 342

Fiore di nome, ma anche di fatto. Realizzata in tecnopolimero, pensata in prima battuta per l'outdoor, Flower, declinata in diversi colori e arricchita di comodi cuscini, viene proposta anche per arredare il salotto di casa, all'insegna di un mood giovane e creativo che cerca ispirazione guardando alle tendenze degli anni 70.

Flower of name, but also of fact. Made in techno polymer, thought in a first step for outdoor, Flower, declined in different colours and enriched with comforts cushions, it is also proposed to furnish the living room of house to the insignnia of a young and creative mood that looks for inspiration looking at the tendencies of the 70's

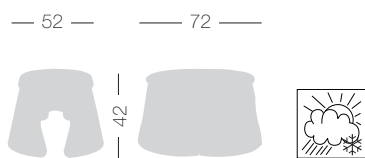
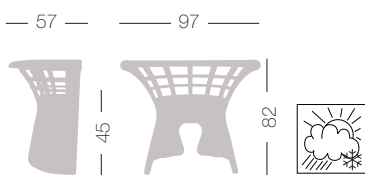

Colori scocca / Shell colours

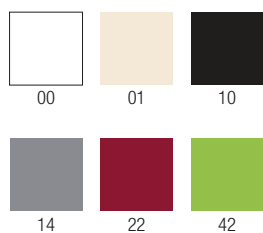



TULIP

Studio Eurolinea

info pag. 357

Giovane e versatile dalle dimensioni contenute, è disponibile in una vasta gamma di colori, si adatta ad ogni tipo di ambiente interno o esterno.

E' impilabile e presente nella collezione Gaber con e senza bracciolo.

Young and versatile with small dimensions, it's available in a wide range of colours. It's suitable for any indoor or outdoor setting.

It's stackable and available with or without arm.

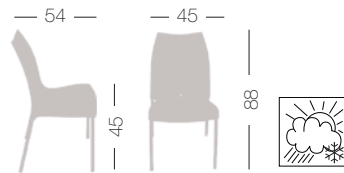

Colori sedia / Chair colours

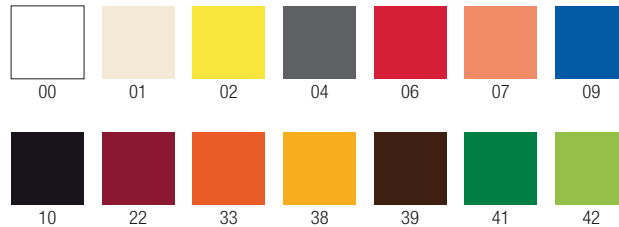

TULIP B

FURNISH THE OUTSIDE LIKE FLOWERS

Studio Eurolinea - info pag. 357





TULIP B

Studio Eurolinea

info pag. 357

Giovane e versatile dalle dimensioni contenute, è disponibile in una vasta gamma di colori, si adatta ad ogni tipo di ambiente interno o esterno.

E' impilabile e presente nella collezione Gaber con e senza bracciolo.

Young and versatile with small dimensions, it's available in a wide range of colours. It's suitable for any indoor or outdoor setting.

It's stackable and available with or without arm.



Colori sedia / Chair colours

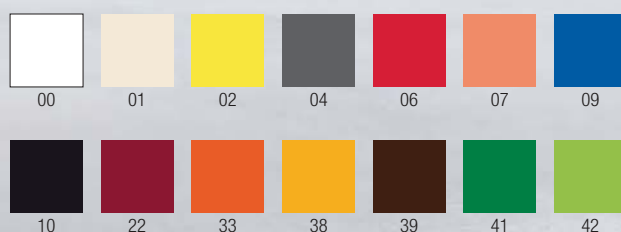
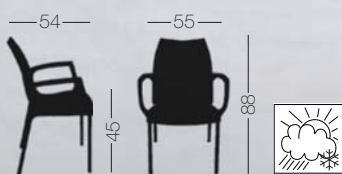



HACKER

Studio Eurolinea

info pag. 343

Hacker è la seduta dal design particolare e dai materiali ricercati. Ottima per un impiego contract, si presta anche ad arredare situazioni residenziali. E' disponibile nella versione con e senza bracciolo.

Hacker is the sitting characterized a by particular design and selected materials. Excellent for a contract context, but it's also suitable for residential ambience. It's available with or without arm.

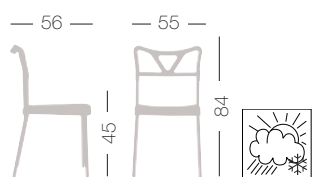

Colori sedia / Chair colours



24

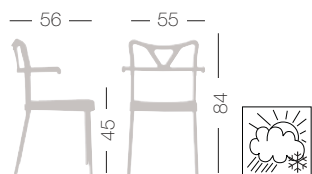

Colori sedia / Chair colours



01

04

10



Colori sedia / Chair colours

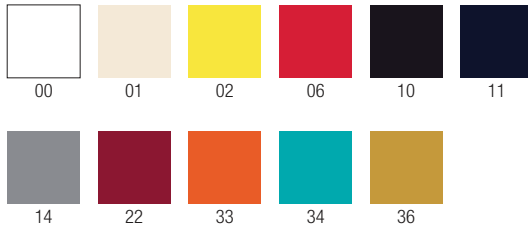
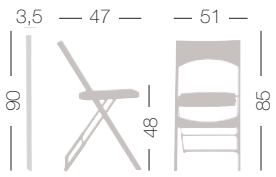

Compact è la sedia pieghevole di Gaber. Disponibile in diversi colori, si contraddistingue per il profilo in alluminio anodizzato e particolari in tecnopolimero; il tutto richiudibile in uno minimo spessore di ingombro di 35 mm.

Compact is the Gaber folding chair. It's available in different colours and it stands for the outline in anodized aluminium and details in techno polymer; the sitting is resalable in a minimum thickness of 35 mm.

COMPACT

Studio Eurolinea

info pag. 341



ve una grande profondità di campo
n'adeguata profondità di sentimento?

William Eugene Smith

OPEN

ORIGINAL OUTSIDE EXPRESSION

Studio Eurolinea - info pag. 349

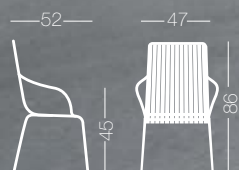

Colori sedia / Chair colours





Un unico pezzo in tecnopolimero che regala alla seduta il naturale monocolore. Ideale per l'arredo bar interno ed esterno, quindi per il contract e la casa. E' una sedia impilabile, facile all'utilizzo e dall'invidiabile comodità.

A unique piece in techno polymer that makes the seat of a natural monochrome. It's ideal both for the inside and outside furniture of a bar and for contract and home ambience. It's a stackable chair, easy to use and enviably comfortable.



PRISMA

Studio Eurolinea

info pag. 351

L'estrema leggerezza è la prima qualità di questo progetto: una seduta straordinariamente moderna realizzata con un nuovo materiale plastico. È disponibile in due versioni imbottite: Firenze e Roma

The overriding characteristic of this piece is its extreme lightness. An extremely modern chair created entirely from a new material.

It is also available in two upholstered version: Firenze and Roma.

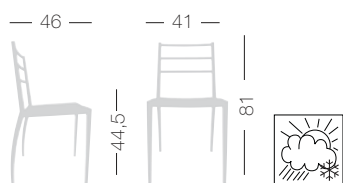

Colori sedia / Chair colours

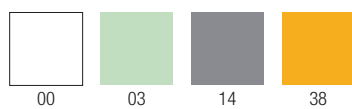

HARMONY

Studio Eurolinea

info pag. 343

E' una sedia poltroncina con struttura in tecnopolimero disponibile in diversi colori ed in 5 differenti versioni di basamenti.

It's a chair with a techno polymer structure available in different colours and with 5 diverse basements.



Colori sedia / Chair colours

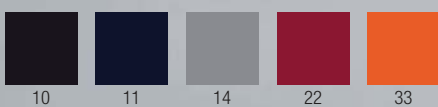

OVER PLUS

THE WARM SENSATION OF UPHOLSTERY

Studio Eurolinea - info pag. 366



Sedia Over Plus rivestita
in ecopelle extrema
disponibile in 5 colori.

Over Plus chair, upholstered
in skai extrema
available in 5 colours.

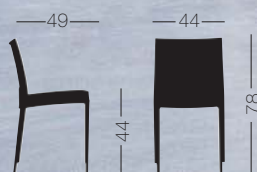

Colori sedia / Chair colours

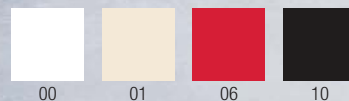

DUCA

LOUNGE EFFECT

info pag. 362



— 70 — — 130 —



Colori pelle / Leather colours

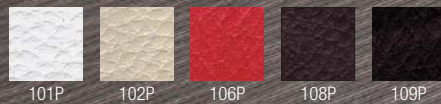



Poltrona e divano rivestiti
in pelle, disponibili in vari
colori. È possibile averli
con vostro tessuto.

Armchair and sofa covering
in leather available in several
colours and it is possible to
covering there with your fabric.



OCTO

HIGH-TECH SHAPE

Stefano Sandonà / info pag. 378

OCTO

Stefano Sandonà

info pag. 378

Il mistico numero otto e il simbolo dell'infinito hanno ispirato questo sgabello dalla forma essenziale e continua, capace di rinnovare l'estetica di ogni tipo di spazio.

The mystic number eight symbol of boundless and have inspired this stool with an essential and continuous, capable of renewing the look of each type of space.

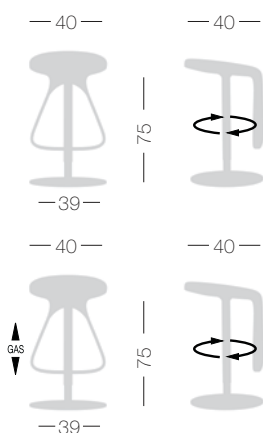

Colori scocca / Shell colours

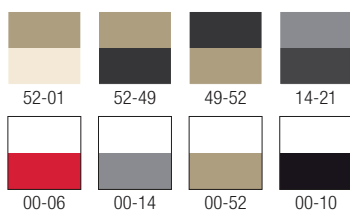



POP

Stefano Sandonà

info pag. 380 / 388

Sgabello bicolore, dotato di maniglia-schienale integrata, confortevole nella seduta e pratico nell'utilizzo, ricco di varianti con sedile in plastica a vista o imbottito, montati su base fissa o regolabile in altezza. La cura dei dettagli e la produzione con materiale tecnopolimero, ne fanno un prodotto di elevata qualità tecnica e di design.

Bicolored stool, endowed with handle-back integrated, comforting in the session and practical in the use, rich of variations with seat in plastics to sight or stuffed, climbed on fixed or adjustable base in height. The care of the details and the production with material techno polymers, do a product of elevated technical quality and design of it.

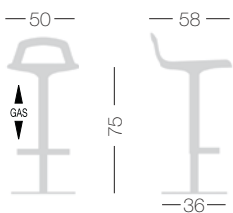

Colori scocca / Shell colours

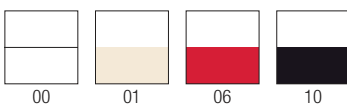

Colori ecopelle Aurea / Aurea skai colours

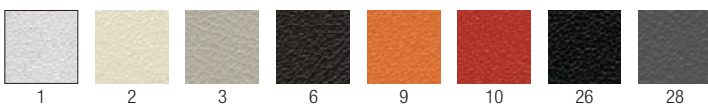



BLOG

Stefano Sandonà

info pag. 371 / 386

Un'allusione alla finestra di messaggi dei diari online, Blog unisce la dolcezza della forma alla leggerezza della struttura per far sorgere uno sgabello pratico e giovanile.

An allusion to the message window of the diaries online, Blog combines the sweetness of the form to the lightness of the structure to give rise to a stool practical and youthful.

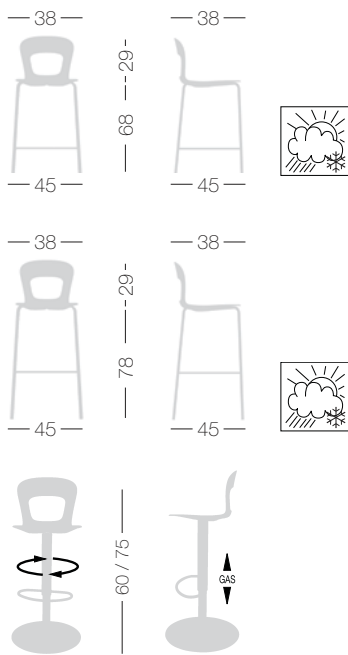

Colori scocca / Shell colours

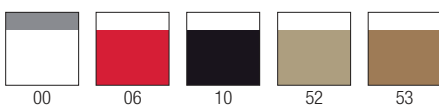

Colori pelle / Leather colours





FREEDOM

Stefano Sandonà

info pag. 373

Espressione pura di velocità e di elevate performance tecniche, nasce Freedom uno sgabello con un design avveniristico dalle linee fluide e taglienti. Realizzato in materiale tecnopolimero ad alte prestazioni. Lo sgabello è disponibile con la base cromata e con l'altezza regolabile o fissa. La seduta è disponibile in diversi colori.

Pure expression of speed and of elevated technical performance, Freedom is the stool with the futuristic design of nautical derivation, essential in its fluid and sharp lines, it is realized in material techno polymer to high performances. The stool is available with the chromed base and with the adjustable or fixed height. The seat is available in different colors.

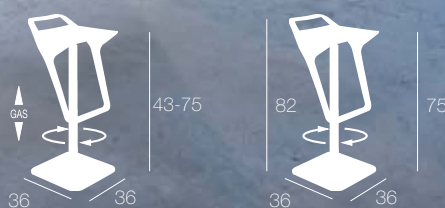

Colori scocca / Shell colours

00-10	00-14	00-21	00-39	14-00	14-21	14-10
21-00	21-10	21-14	10-00	10-21	10-14	

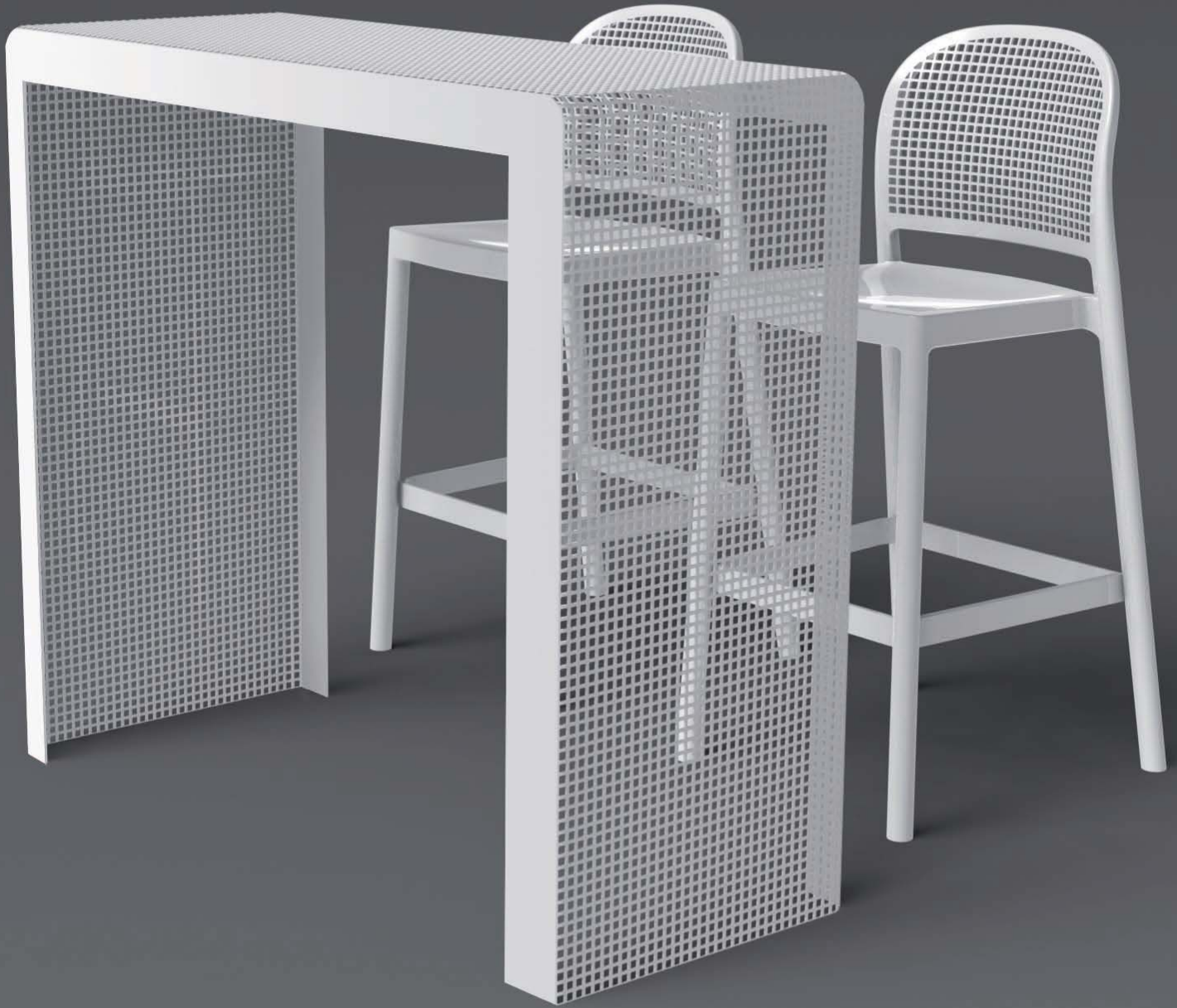

PANAMA

Stefano Sandonà

info pag. 379

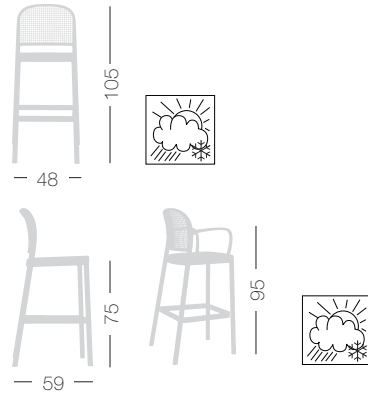

Colori scocca / *Shell colours*

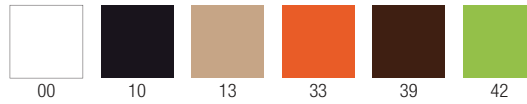

Colori ecopelle Aurea / *Aurea skai colours*

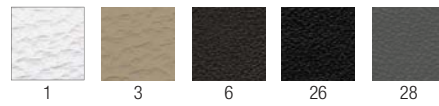

Colori tessuto King / *King fabric colours*

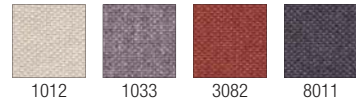

Innovazione tecnologica e grande ricerca nell'utilizzo dei materiali danno vita a questo sgabello dalle linee morbide ed attuali.

The stool was born from technological research and experimentation in the use of materials. The soft and actual lines countersign its design.





MICRO

R&D Gaber

info pag. 377

Sgabello con telaio in metallo cromato ed altezza regolabile (MICRO) o fissa (MIX). La seduta è in tecnopolimero e la base può essere in colore abbinato o in inox. Disponibile anche nella versione rivestito Mod. Asolo.

Barstool with chromed frame and gas adjustable (MICRO) or fixed (MIX). The shell is in techno polymer and the base can be of the same colour of the seat or in stainless steel. It's also available in covering version Mod. Asolo.

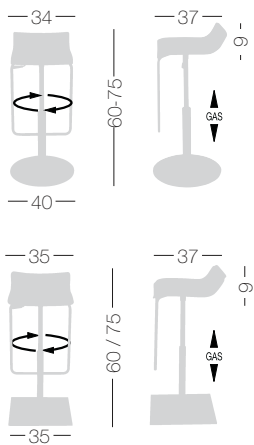

Colori / Colours

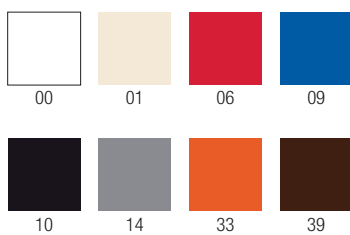

ASOLO

R&D Gaber

info pag. 385

Sgabello con telaio in metallo cromato ed altezza regolabile. La seduta è in cuoio con base inox cromata. Disponibile nella versione non imbottita, Mod. Micro.

Barstool with chromed frame and gas adjustable. The seat is in leather with chromed frame and stainless steel base. Also available in no covering version Mod. Micro.

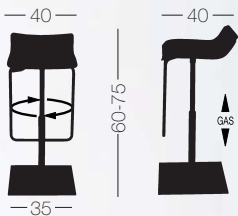
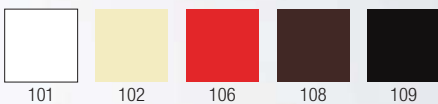
Colori cuoio / *Leather colours*

MOEMA

WELCOME BACK TO THE FUTURE

Stefano Sandonà / info pag. 377

Sgabello con telaio in metallo cromato e base cromata. La seduta è disponibile in diversi colori coprenti e trasparenti.

Barstool with chromed frame and base. The seat is available in different coating and transparent colours.

**GOOD
DESIGN
AWARD** OF CHICAGO
ATHENAEUM :
MUSEUM OF
ARCHITECTURE
AND DESIGN





ALHAMBRA

Stefano Sandonà

info pag. 370

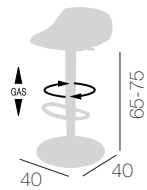
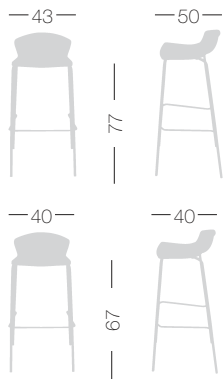

Sgabello con telaio in metallo cromato o verniciato per esterno con seduta in tecnopolimero bicolore, disponibile in diverse combinazioni di colore.

Stool in chromed or painted metal and techno polymer seat available in several colours.

Colori scocca / Shell colours

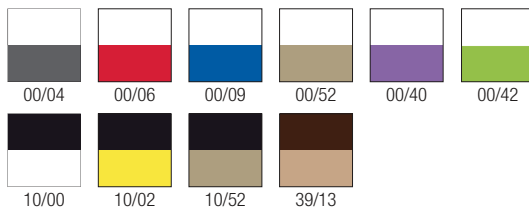



ALHAMBRA

Stefano Sandonà

info pag. 384

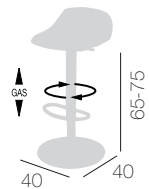
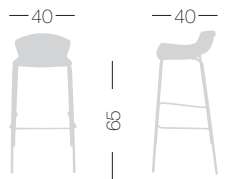
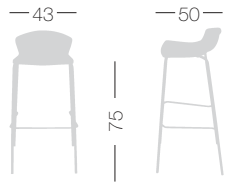

Sgabello con telaio in metallo cromato con seduta in tecnopolimero e disponibile in diverse combinazioni di colore.

Stool in chromed metal and techno polymer seat available in several colours.

Colori tessuto Opis / Opis fabric colours

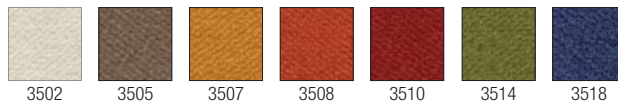

Colori ecopelle Aurea / Aurea skai colours

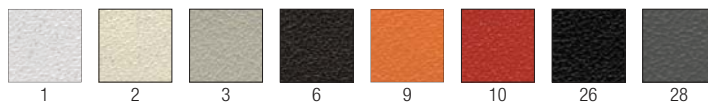

GULIVER, FREE

R&D Gaber

info pag. 373

Sgabello con telaio in metallo cromato disponibile con altezza regolabile (Guliver) o solamente girevole (Free). La seduta è in tecnopolimero abbinata alle base dello stesso colore o cromata.

Barstool with chromed frame available with gas adjustable (Guliver) or swivel (Free). The seat is in techno polymer matched to the same colour or chromed base.

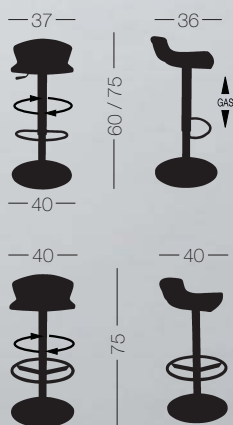

Colori scocca / Shell colours





TORINO

Stefano Sandonà

info pag. 388

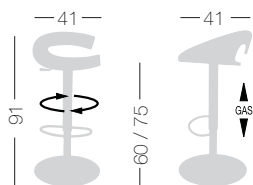

Colori pelle / Leather colours



101P



102P



106P



108P



109P



OFER

R&D Gaber

info pag. 378

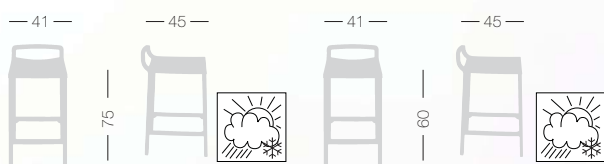

Colori / Colours

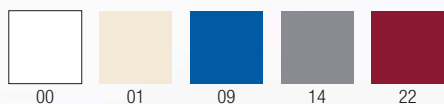

Seduta e poggiatesta in tecnopolimero e struttura metallica in alluminio anodizzato. Disponibile in altezza 75cm, 60cm. Vasta gamma di colori.

Seat and footrest in techno polymer and anodized aluminium legs. It is available in 75cm, 60cm height. Large range of colours.





Seduta e poggiatesta in ecopelle e struttura metallica in alluminio anodizzato. Disponibile in altezza 75cm, 60cm. Vasta gamma di colori. Disponibile la versione non rivestita Mod. Liberty

Seat and footrest in skai and anodized aluminium legs. It is available in 75cm, 60cm height. Large range of colours. Also available no covering version Liberty.

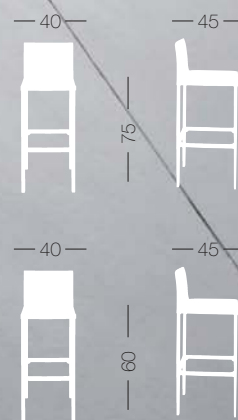

Colori ecopelle Extrema / Extrema skai colours





EASY

R&D Gaber

info pag. 372

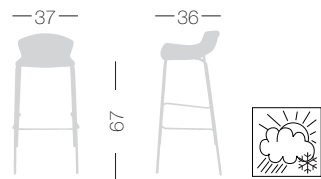
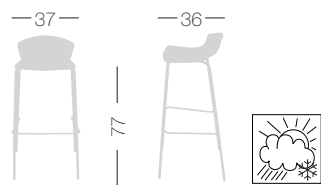

Sgabello con telaio in metallo cromato o verniciato per esterno con seduta in tecnopolimero, è disponibile in diverse combinazioni di colore. Impilabile.

Stool in chromed or painted metal and techno polymer seat available in several colours. Stackable.

Colori / Colours

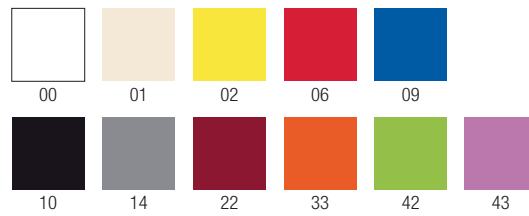



TEO

R&D Gaber

info pag. 383

Il Design originale, raffinato e la particolarità dell'intreccio garantiscono una perfetta versatilità d'uso del prodotto. Incredibilmente simile alla fibra naturale, non necessita di manutenzione periodica e garantisce ottime caratteristiche di resistenza agli agenti atmosferici. Questo modello è disponibile in 4 varianti colore.

The original Design, refined and the particularity of the interlacement they guarantee a perfect versatility of use of the product. Incredibly similar to the natural fiber, doesn't need periodic maintenance and guarantees good characteristics of resistance to the atmospheric agents. This model is available in 4 varying color.

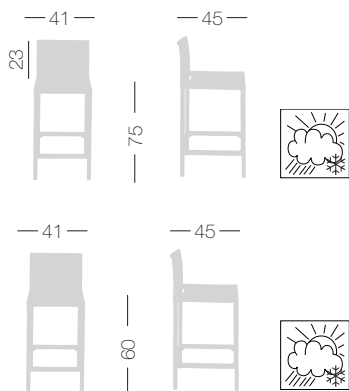

Colori / Colours

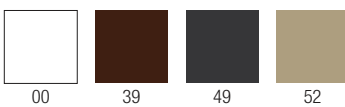



SOFT

RUDE LOOK THAT PLAY WITH CONTRASTS

R&D Gaber - info pag. 381

Sgabello con telaio in metallo cromato, altezza regolabile e base gaber in tecnopolimero abbinato alla seduta o cromata.

Gas adjustable stool with frame in chromed steel, techno polymer seat and base colour matching or chromed.

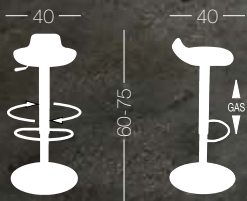

Colori / Colours



MAX

SO MANY HEIGHTS TO REACH THE RIGHT LEVEL

R&D Gaber - info pag. 376



Seduta e poggiatesta in tecnopolimero e struttura metallica in alluminio anodizzato. Disponibile in altezza 80cm, 75cm, 60cm e 42cm. Vasta gamma di colori.

Seat and footrest in techno polymer and anodized aluminium legs. It is available in 80cm, 75cm, 60cm, 42cm height. Large range of colours.



Colori / Colours

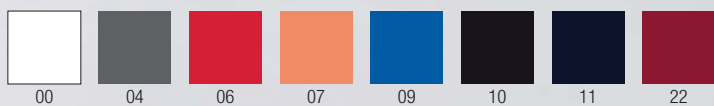







ROLLER

Studio Eurolinea

Collezione di tavoli
da interno ed esterno
con base in tecnopolimero
e piani in compactop.
Altezza 110 disponibile
in versione luminosa.

Collection of tables for
indoor and outdoor use.
The base is in technopolymer
and compact tops.
With height 110 are also bright.

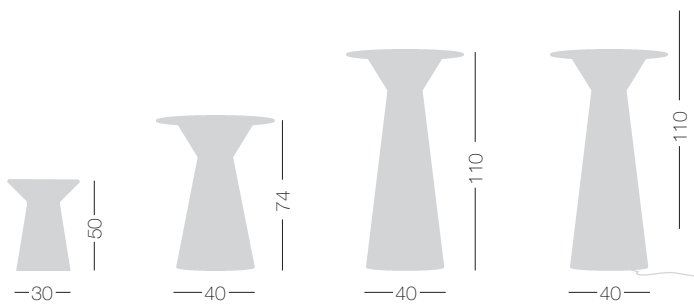

Colori / Colours

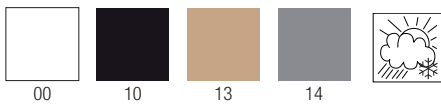

Piani compactop / Compactop tops

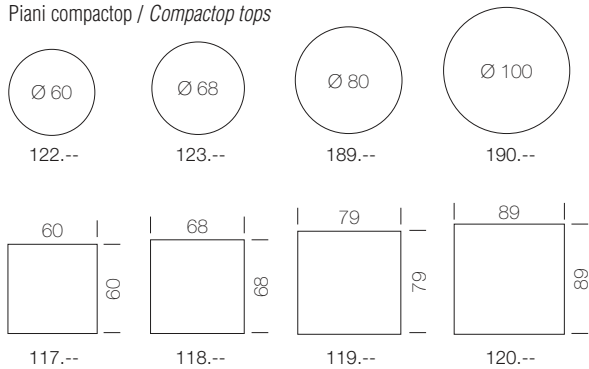









FLAIRE

Studio Eurolinea

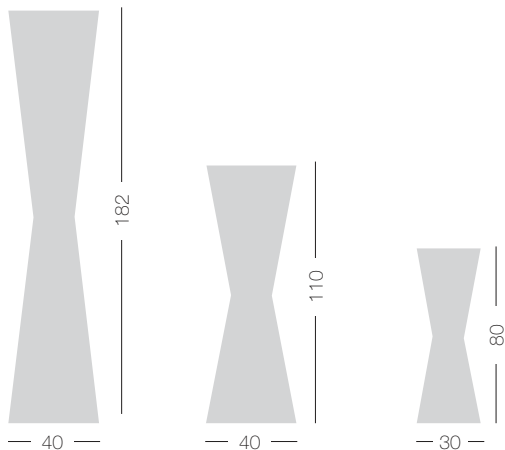

Collezione di lampade
in materiale plastico
con effetto a bagliore diffuso.

Lamp collection made
by technopolymer
with diffused shine effect.

Colori / Colours



00

